



Description

Metal Oxide Varistor (MOV) as one nonlinear resistance element is mainly made of zinc oxide (ZnO), which has very high surge capacity and big nonlinear coefficient. Below the threshold voltage, its resistance is very high, nearly no current flows through, but above the threshold voltage, the resistance reduces sharply, huge current can be discharged. Due to this characteristic, varistor as a protection component in electronic and electrical equipment can absorb abnormal over-voltage and lightning surge.

SETsafe | SETfuse varistor is with High Surge Current Density, Low Clamping Voltage, and Good Surge Capacity. It can also be customized as required.

Features

- Epoxy Resin Coating
- Silicone Resin Coating
- Low Leakage Current
- Bidirectional and Symmetrical V/I Characteristics
- RoHS & REACH Compliant

Applications

- Power Supplies
- Home Electrical Appliances
- Industrial Devices
- Surge Protectors
- Telecom Devices

Product Structure

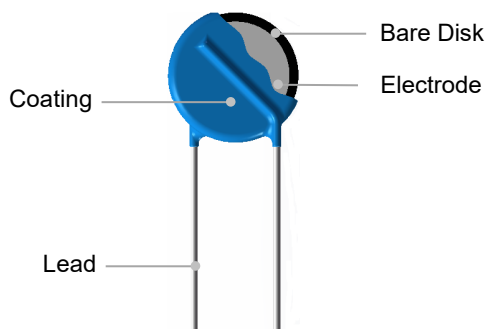

Lead Types

Lead Types		Codes
	Straight Lead	A
	Inward Crimp Lead	B
	Outward Crimp Lead	C
	Inline Crimp Lead	D
	Little Straight Lead	I

Agency Approvals

Agency	Standards	No.
	UL 1449 4 th Edition	E322662
	CSA C22.2 NO.269.5-17	E322662
	EN IEC 61051-1:2008 IEC 61051-2:1991+A1 IEC 61051-2-2:1991 Annex G.8.1 of IEC 62368-1:2018	J 50500868
	GB/T 10193-1997 GB/T 10194-1997 GB 4943.1-2011 GB 8898-2011	CQC21001292475

Marking

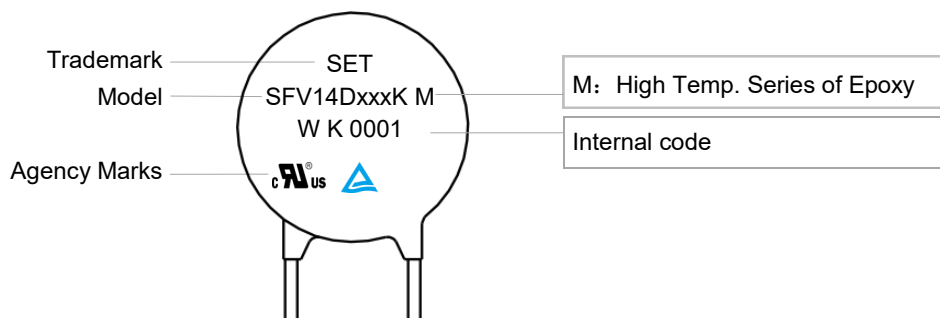

MOV

MOV

Temp. Derating Curve

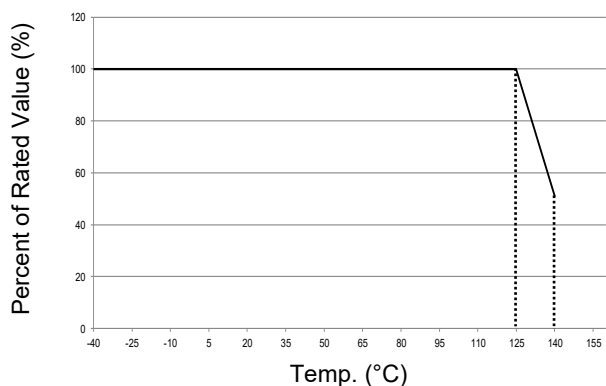

Note:

For high temp. series, when ambient temp. exceeds 125 °C, the peak surge current and energy rating should be reduced as shown in the left curve.

For High Temp. Series Products

General Technical Data

Item	Value	Unit
Operating Temperature	-40 to +125	°C
Storage Temperature	-40 to +150	°C
Voltage Proof	≥1000	V _{ac}
Insulation Resistance	≥100	MΩ

Part Numbering System

SFV 14 D 471 - K M K A BUL - 001

MOV

MOV

Other Options

***Packaging & Lead Length**

BUL: Bulk + Standard Lead Length (Normal L28)
 C35: Bulk + Cut to 3.5 mm (Range:2.5 mm to 6 mm)
 L30: Bulk + Special Lead Length 30 mm (28 mm to 32 mm)
 (0/1)AB: Taping + Box (Hole Pitch 12.7 mm)
 (0/1)EB: Taping + Box (Hole Pitch 15.0 mm)
 (0/1)AR: Taping + Reel (Hole Pitch 12.7 mm)
 (0/1)ER: Taping + Reel (Hole Pitch 15.0 mm)
 Note:0/1 Means Product Position

Lead Types

A: Straight Lead
 B: Inward Crimp Lead
 C: Outward Crimp Lead
 D: Inline Crimp Lead
 I : Little Straight Lead

Surge Level

S: Normal Type
 K: Standard Type
 Q: Advanced Type
 H: High Energy Type

Operating Temp.

M: Epoxy Coating 125 °C

Voltage Tolerance

K: ±10%
 J: ±5%
 S: Special Tolerance

Nominal Varistor Voltage

220: $22 \times 10^0 = 22 \text{ V}$
 471: $47 \times 10^1 = 470 \text{ V}$
 122: $12 \times 10^2 = 1200 \text{ V}$

Disk Shape

D: Round

Bare Disk Dimension

14: 14 mm

Product Category

SETfuse Varistor

*For more details refer to packaging information.

Glossary

Item	Description
V_N	Nominal Varistor Voltage Voltage, at specified D.C. current used as a reference point in the component characteristics.
I_L	Leakage Current Measuring at 75% of varistor voltage.
UCT	Upper Category Temp. Max. ambient temp. for which a varistor has been designed to operate continuously.
LCT	Lower Category Temp. Minimum ambient temp. at which a varistor has been designed to operate continuously.
Max. Peak Current	Max. Peak Current Max. current per pulse, which may be passed by a varistor at an ambient temp. of 25 °C, for a given number of pulses.
V_C	Clamping Voltage Peak voltage developed across the varistor terminations under standard atmospheric conditions, when passing an 8/20 μ s class current pulse.
Voltage Proof	Voltage Proof Max. peak voltage, which may be applied under continuous operating conditions between the varistor terminations and any conducting mounting surface (Applicable only to insulated varistors).
C_V	Capacitance Capacitance across the MOV measured at a specified frequency and voltage.
V_{ac}	Max. Continuous a.c. Voltage Max. a.c. r.m.s. voltage of a substantially sinusoidal waveform (less than 5% total harmonic distortion) which can be applied to the component under continuous operating conditions at 25 °C.
V_{dc}	Max. Continuous d.c. Voltage Max. d.c. voltage (with less than 5% ripple) which can be applied to the component under continuous operating conditions at an ambient temp. of 25 °C.

Dimensions (mm)

Model	L (Min.)	H (Max.)	T (Max.)	D (Max.)	d	F	F ₁	A (Max.)
SFV14D820KM	20	18.5	4.4	16.5	0.80±0.05	7.5±0.6	1.2 - 2.6	21.5
SFV14D101KM	20	18.5	4.6	16.5	0.80±0.05	7.5±0.6	1.3 - 2.8	21.5
SFV14D121KM	20	18.5	4.8	16.5	0.80±0.05	7.5±0.6	1.4 - 3.0	21.5
SFV14D151KM	20	18.5	5.1	16.5	0.80±0.05	7.5±0.6	1.6 - 3.3	21.5
SFV14D181KM	20	18.5	4.5	16.5	0.80±0.05	7.5±0.6	1.3 - 2.8	21.5 ₃
SFV14D201KM	20	18.5	4.6	16.5	0.80±0.05	7.5±0.6	1.3 - 2.9	21.5
SFV14D221KM	20	18.5	4.7	16.5	0.80±0.05	7.5±0.6	1.4 - 3.0	21.5
SFV14D241KM	20	18.5	4.9	16.5	0.80±0.05	7.5±0.6	1.4 - 3.1	21.5
SFV14D271KM	20	18.5	5.0	16.5	0.80±0.05	7.5±0.6	1.5 - 3.3	21.5
SFV14D301KM	20	18.5	5.2	16.5	0.80±0.05	7.5±0.6	1.7 - 3.5	21.5
SFV14D331KM	20	18.5	5.4	16.5	0.80±0.05	7.5±0.6	1.8 - 3.6	21.5
SFV14D361KM	20	18.5	5.6	16.5	0.80±0.05	7.5±0.6	1.9 - 3.8	21.5
SFV14D391KM	20	18.5	5.7	16.5	0.80±0.05	7.5±0.6	2.0 - 4.0	21.5
SFV14D431KM	20	18.5	6.0	16.5	0.80±0.05	7.5±0.6	2.2 - 4.2	21.5
SFV14D471KM	20	18.5	6.2	16.5	0.80±0.05	7.5±0.6	2.4 - 4.4	21.5
SFV14D511KM	20	18.5	6.4	16.5	0.80±0.05	7.5±0.6	2.6 - 4.6	21.5
SFV14D561KM	20	18.5	6.7	16.5	0.80±0.05	7.5±0.6	2.9 - 4.9	21.5
SFV14D621KM	20	18.5	7.1	16.5	0.80±0.05	7.5±0.6	3.2 - 5.2	21.5
SFV14D681KM	20	18.5	7.4	16.5	0.80±0.05	7.5±0.6	3.6 - 5.6	21.5
SFV14D751KM	20	18.5	7.9	16.5	0.80±0.05	7.5±0.6	4.0 - 6.0	21.5
SFV14D821KM	20	18.5	8.3	16.5	0.80±0.05	7.5±0.6	4.4 - 6.4	21.5
SFV14D911KM	20	18.5	8.8	16.5	0.80±0.05	7.5±0.6	4.9 - 6.9	21.5
SFV14D102KM	20	18.5	9.3	16.5	0.80±0.05	7.5±0.6	5.4 - 7.4	21.5
SFV14D112KM	20	18.5	9.9	16.5	0.80±0.05	7.5±0.6	5.9 - 7.9	21.5
SFV14D122KM	20	18.5	10.5	16.5	0.80±0.05	7.5±0.6	6.5 - 8.5	21.5

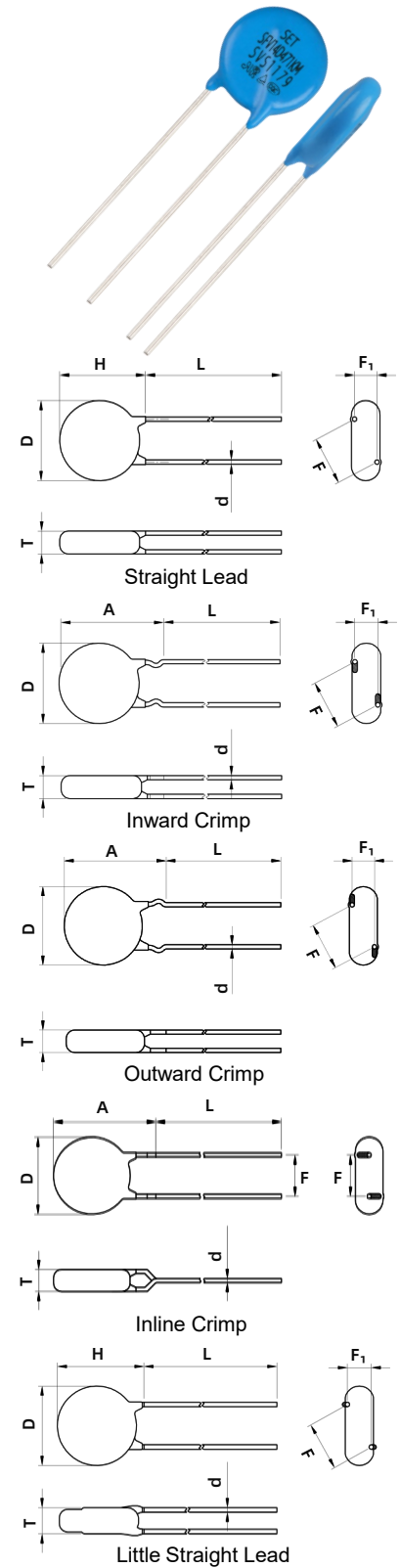

Note:
The above data is for reference only.

MOV

MOV

Specification

Model	Surge Level	Max. Continuous Operating Voltage		Varistor Voltage @1 mA DC		Clamping Voltage (Max.)		Max. Peak Current (1 time, 8/20 μs)	Max. Energy (10/1000 μs)	Typical Capacitance (For reference only) @1 kHz	Agency Approvals						
		Vac	Vdc	Min.	Max.	V _C	I _P				S		(pF)	UL	CUL	TUV	CQC
		(V)	(V)	(V)	(V)	(V)	(A)				(kA)	(J)		UL	CUL	TUV	CQC
SFV14D820KM	S	50	65	74	90	135	50	4.5	22	2400	●	●	●	●			
SFV14D101KM	S	60	85	90	110	165	50	4.5	28	2000	●	●	●	●			
SFV14D121KM	S	75	100	108	132	200	50	4.5	32	1700	●	●	●	●			
SFV14D151KM	S	95	125	135	165	250	50	4.5	40	1300	●	●	●	●			
SFV14D181KM	S	115	150	162	198	300	50	4.5	50	1100	●	●	●	●			
SFV14D201KM	S	130	170	180	220	340	50	4.5	57	1000	●	●	●	●			
SFV14D221KM	S	140	180	198	242	360	50	4.5	60	900	●	●	●	●			
SFV14D241KM	S	150	200	216	264	395	50	4.5	63	830	●	●	●	●			
SFV14D271KM	S	175	225	243	297	455	50	4.5	70	740	●	●	●	●			
SFV14D301KM	S	190	250	270	330	500	50	4.5	77	670	●	●	●	●			
SFV14D331KM	S	210	275	297	363	550	50	4.5	85	610	●	●	●	●			
SFV14D361KM	S	230	300	324	396	595	50	4.5	93	560	●	●	●	●			
SFV14D391KM	S	250	320	351	429	650	50	4.5	100	510	●	●	●	●			
SFV14D431KM	S	275	350	387	473	710	50	4.5	115	460	●	●	●	●			
SFV14D471KM	S	300	385	423	517	775	50	4.5	125	430	●	●	●	●			
SFV14D511KM	S	320	415	459	561	845	50	4.5	125	390	●	●	●	●			
SFV14D561KM	S	350	460	504	616	925	50	4.5	125	360	●	●	●	●			
SFV14D621KM	S	385	505	558	682	1025	50	4.5	125	320	●	●	●	●			
SFV14D681KM	S	420	560	612	748	1120	50	4.5	130	290	●	●	●	●			
SFV14D751KM	S	460	615	675	825	1240	50	4.5	143	270	●	●	●	●			
SFV14D821KM	S	510	670	738	902	1355	50	4.5	157	240	●	●	●	●			
SFV14D911KM	S	550	745	819	1001	1500	50	4.5	175	220	●	●	●	●			
SFV14D102KM	S	625	825	900	1100	1650	50	4.5	190	200	●	●	●	●			
SFV14D112KM	S	680	895	990	1210	1815	50	4.5	213	180	●	●	●	●			
SFV14D122KM	S	750	990	1080	1320	1980	50	4.5	213	150	●	●	●	●			

● : Approved ○ : No application for certification

MOV

MOV

Specification

Model	Surge Level	Max. Continuous Operating Voltage		Varistor Voltage @1 mA DC		Clamping Voltage (Max.)		Max. Peak Current (1 time, 8/20 μs)	Max. Energy (10/1000 μs)	Typical Capacitance (For reference only) @1 kHz	Agency Approvals						
		Vac	Vdc	Min.	Max.	V _c	I _p				K		(pF)	UL	CUL	TUV	CQC
		(V)	(V)	(V)	(V)	(V)	(A)				(kA)	(J)					
SFV14D820KM	K	50	65	74	90	135	50	6	28	2400	●	●	●	●			
SFV14D101KM	K	60	85	90	110	165	50	6	35	2000	●	●	●	●			
SFV14D121KM	K	75	100	108	132	200	50	6	42	1700	●	●	●	●			
SFV14D151KM	K	95	125	135	165	250	50	6	53	1300	●	●	●	●			
SFV14D181KM	K	115	150	162	198	300	50	6	60	1100	●	●	●	●			
SFV14D201KM	K	130	170	180	220	340	50	6	70	1000	●	●	●	●			
SFV14D221KM	K	140	180	198	242	360	50	6	78	900	●	●	●	●			
SFV14D241KM	K	150	200	216	264	395	50	6	84	830	●	●	●	●			
SFV14D271KM	K	175	225	243	297	455	50	6	99	740	●	●	●	●			
SFV14D301KM	K	190	250	270	330	500	50	6	108	670	●	●	●	●			
SFV14D331KM	K	210	275	297	363	550	50	6	115	610	●	●	●	●			
SFV14D361KM	K	230	300	324	396	595	50	6	130	560	●	●	●	●			
SFV14D391KM	K	250	320	351	429	650	50	6	140	510	●	●	●	●			
SFV14D431KM	K	275	350	387	473	710	50	6	155	460	●	●	●	●			
SFV14D471KM	K	300	385	423	517	775	50	6	175	430	●	●	●	●			
SFV14D511KM	K	320	415	459	561	845	50	6	180	390	●	●	●	●			
SFV14D561KM	K	350	460	504	616	925	50	6	185	360	●	●	●	●			
SFV14D621KM	K	385	505	558	682	1025	50	6	190	320	●	●	●	●			
SFV14D681KM	K	420	560	612	748	1120	50	6	200	290	●	●	●	●			
SFV14D751KM	K	460	615	675	825	1240	50	6	210	270	●	●	●	●			
SFV14D821KM	K	510	670	738	902	1355	50	6	235	240	●	●	●	●			
SFV14D911KM	K	550	745	819	1001	1500	50	6	255	220	●	●	●	●			
SFV14D102KM	K	625	825	900	1100	1650	50	6	270	200	●	●	●	●			
SFV14D112KM	K	680	895	990	1210	1815	50	6	280	180	●	●	●	●			
SFV14D122KM	K	750	990	1080	1320	1980	50	6	310	150	●	●	●	●			

●: Approved ○: No application for certification

MOV

MOV

Specification

Model	Surge Level	Max. Continuous Operating Voltage		Varistor Voltage @1 mA DC		Clamping Voltage (Max.)		Max. Peak Current (1 time, 8/20 μs)	Max. Energy (8/20 μs)	Typical Capacitance (For reference only) @1 kHz	Agency Approvals					
		Vac	Vdc	Min.	Max.	V _C	I _P				H		UL	CUL	TUV	CQC
		(V)	(V)	(V)	(V)	(V)	(A)				(kA)	(J)				
SFV14D201KM	H	130	170	180	220	340	50	8	150	1000	●	●	●	●		
SFV14D221KM	H	140	180	198	242	360	50	8	160	900	●	●	●	●		
SFV14D241KM	H	150	200	216	264	395	50	8	180	830	●	●	●	●		
SFV14D271KM	H	175	225	243	297	455	50	8	200	740	●	●	●	●		
SFV14D301KM	H	190	250	270	330	500	50	8	220	670	●	●	●	●		
SFV14D331KM	H	210	275	297	363	550	50	8	245	610	●	●	●	●		
SFV14D361KM	H	230	300	324	396	595	50	8	260	560	●	●	●	●		
SFV14D391KM	H	250	320	351	429	650	50	8	290	510	●	●	●	●		
SFV14D431KM	H	275	350	387	473	710	50	8	320	460	●	●	●	●		
SFV14D471KM	H	300	385	423	517	775	50	8	350	430	●	●	●	●		
SFV14D511KM	H	320	415	459	561	845	50	8	380	390	●	●	●	●		
SFV14D561KM	H	350	460	504	616	925	50	8	400	360	●	●	●	●		
SFV14D621KM	H	385	505	558	682	1025	50	8	400	320	●	●	●	●		
SFV14D681KM	H	420	560	612	748	1120	50	8	400	290	●	●	●	●		

Model	Surge Level	Max. Continuous Operating Voltage		Varistor Voltage @1 mA DC		Clamping Voltage (Max.)		Pulse Impact Performance (40 times) (1.2/50 μs & 8/20 μs)	Max. Energy (10/1000 μs)	Typical Capacitance (For reference only) @1 kHz	Agency Approvals					
		Vac	Vdc	Min.	Max.	V _C	I _P				Q		UL	CUL	TUV	CQC
		(V)	(V)	(V)	(V)	(V)	(A)				(kV)	(J)				
SFV14D201KM	Q	130	170	180	220	340	50	6.6	70	1000	●	●	●	●		
SFV14D221KM	Q	140	180	198	242	360	50	6.6	78	900	●	●	●	●		
SFV14D241KM	Q	150	200	216	264	395	50	6.6	84	830	●	●	●	●		
SFV14D271KM	Q	175	225	243	297	455	50	6.6	99	740	●	●	●	●		
SFV14D301KM	Q	190	250	270	330	500	50	6.6	108	670	●	●	●	●		
SFV14D331KM	Q	210	275	297	363	550	50	6.6	115	610	●	●	●	●		
SFV14D361KM	Q	230	300	324	396	595	50	6.6	130	560	●	●	●	●		
SFV14D391KM	Q	250	320	351	429	650	50	6.6	140	510	●	●	●	●		
SFV14D431KM	Q	275	350	387	473	710	50	6.6	155	460	●	●	●	●		
SFV14D471KM	Q	300	385	423	517	775	50	6.6	175	430	●	●	●	●		
SFV14D511KM	Q	320	415	459	561	845	50	6.6	180	390	●	●	●	●		
SFV14D561KM	Q	350	460	504	616	925	50	6.6	185	360	●	●	●	●		
SFV14D621KM	Q	385	505	558	682	1025	50	6.6	190	320	●	●	●	●		
SFV14D681KM	Q	420	560	612	748	1120	50	6.6	200	290	●	●	●	●		

MOV

MOV

Performance Curve (For reference only)

- Max. Peak Current Derating Curves

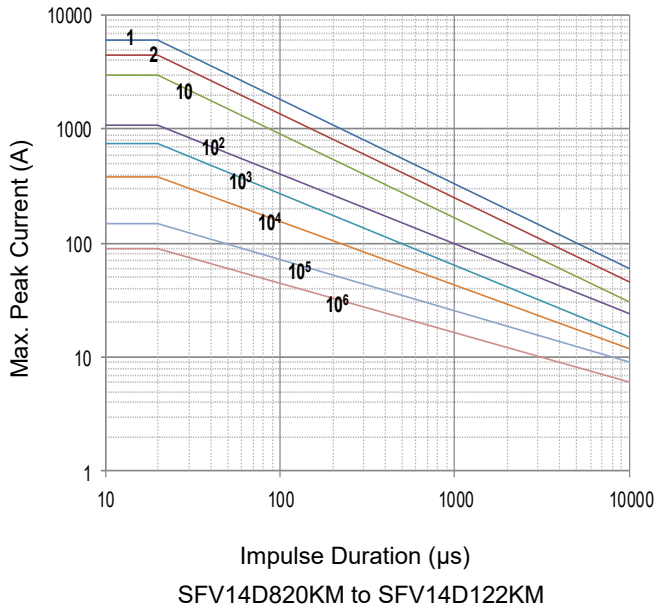

Note: 1, 2, 10, 10², 10³, 10⁴, 10⁵, 10⁶ Stand for Repetitions.

- Voltage-Current Characteristic Curves

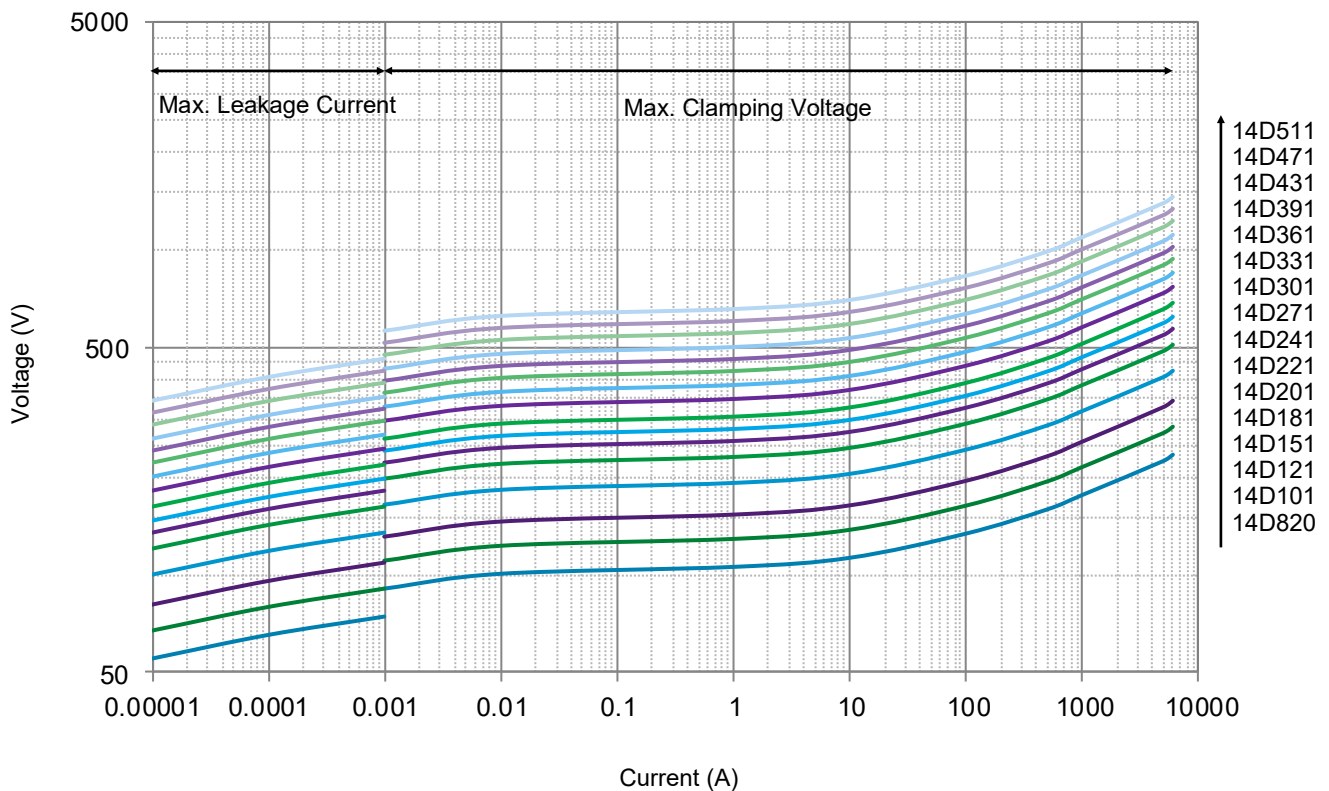

• Voltage-Current Characteristic Curves

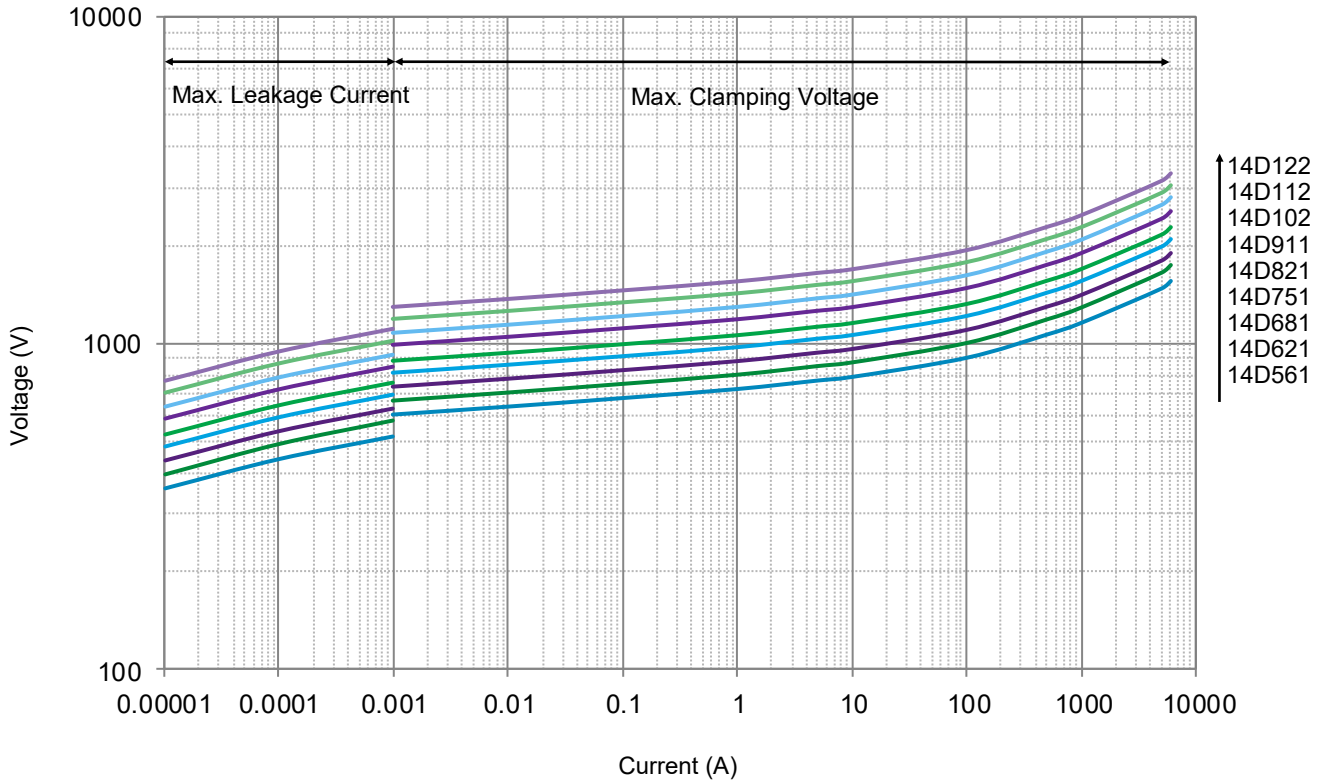

MOV

MOV

Soldering Parameters

Wave Soldering Parameters

The wave soldering parameters are for reference only. When MOV is for practice use, some related validation is recommended.

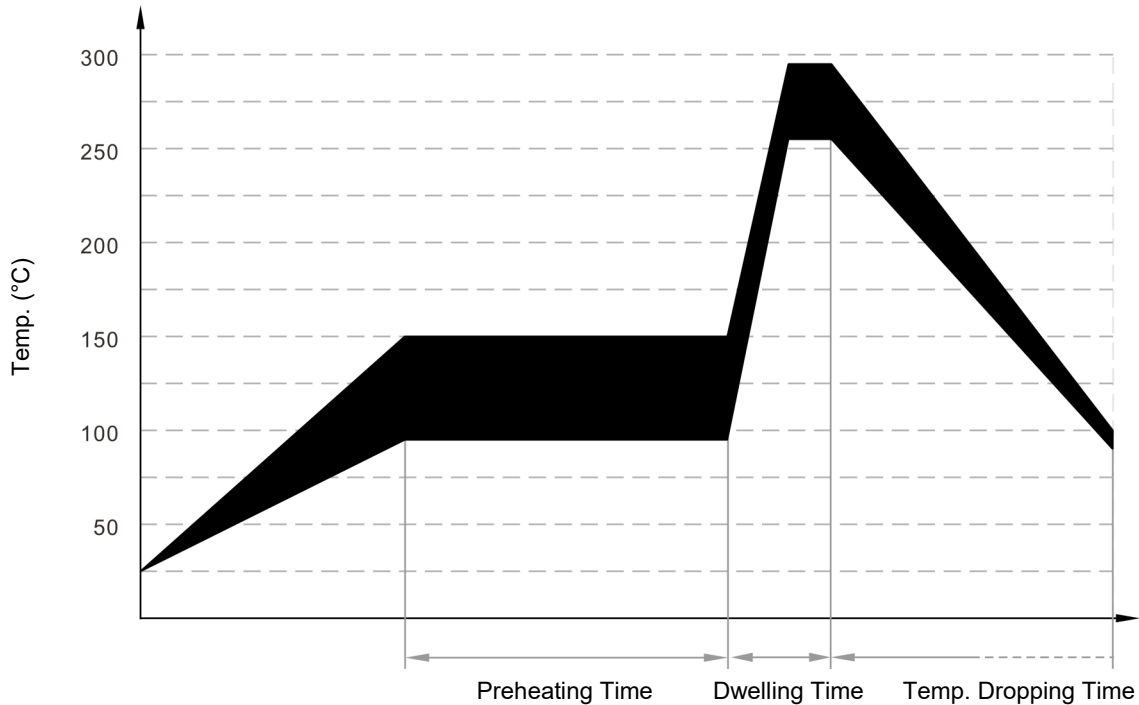

Wave Soldering Curve

Item	Temp. (°C)	Time (s)
Preheating	90 to 150	<150
Dwelling	255 to 290	3 to 10

Recommended Hand-Soldering Parameters

Item	Condition
Temp. of Solder Head	350 °C (max.)
Soldering Time	4 seconds (max.)

Packaging Information

- Bulk Packaging (Code: BUL)
- Bulk Packaging Quantity & Weight.

Series	Nominal Varistor Voltage	PE Bag	Box	Carton	G. W / Carton (365 × 265 × 245)
	(V)	(PCS)	(PCS)	(PCS)	(kg)±10%
14D	820 - 361	500	1000	6000	8 - 15
	391 - 621	400	800	4800	13 - 18
	681 - 122	250	500	3000	12 - 20

Note:

Other lead length packaging information, please contact SETsafe | SETfuse.

All Dimensions in mm

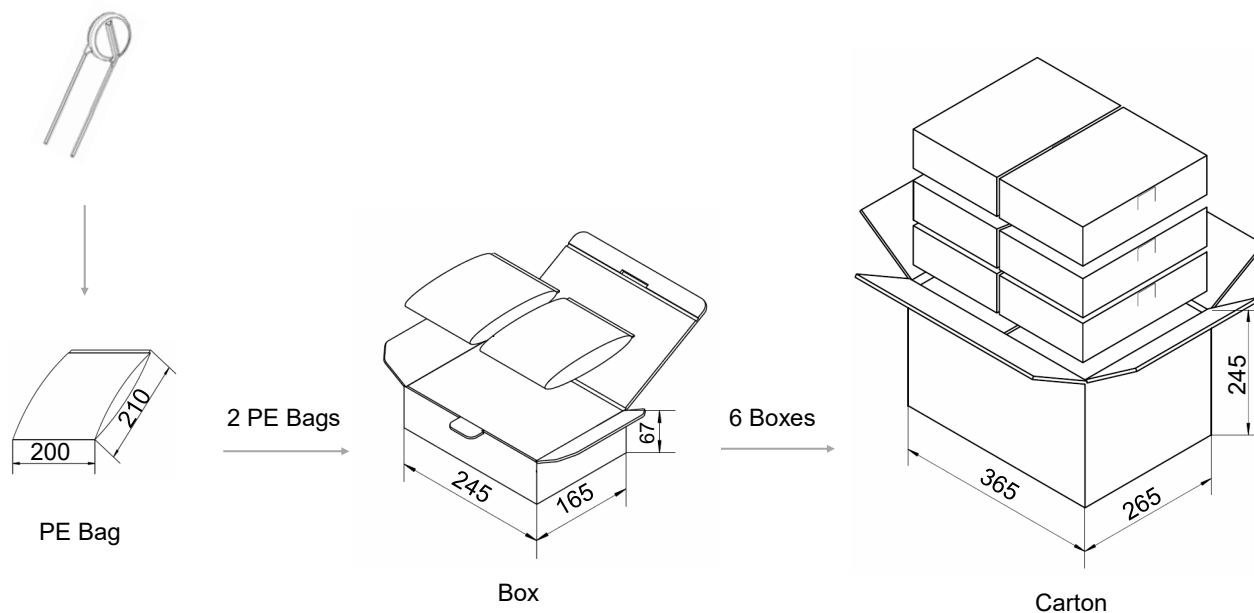

Packaging Information

- Tape Packaging (Code: 0AB)

Dimensions (mm)

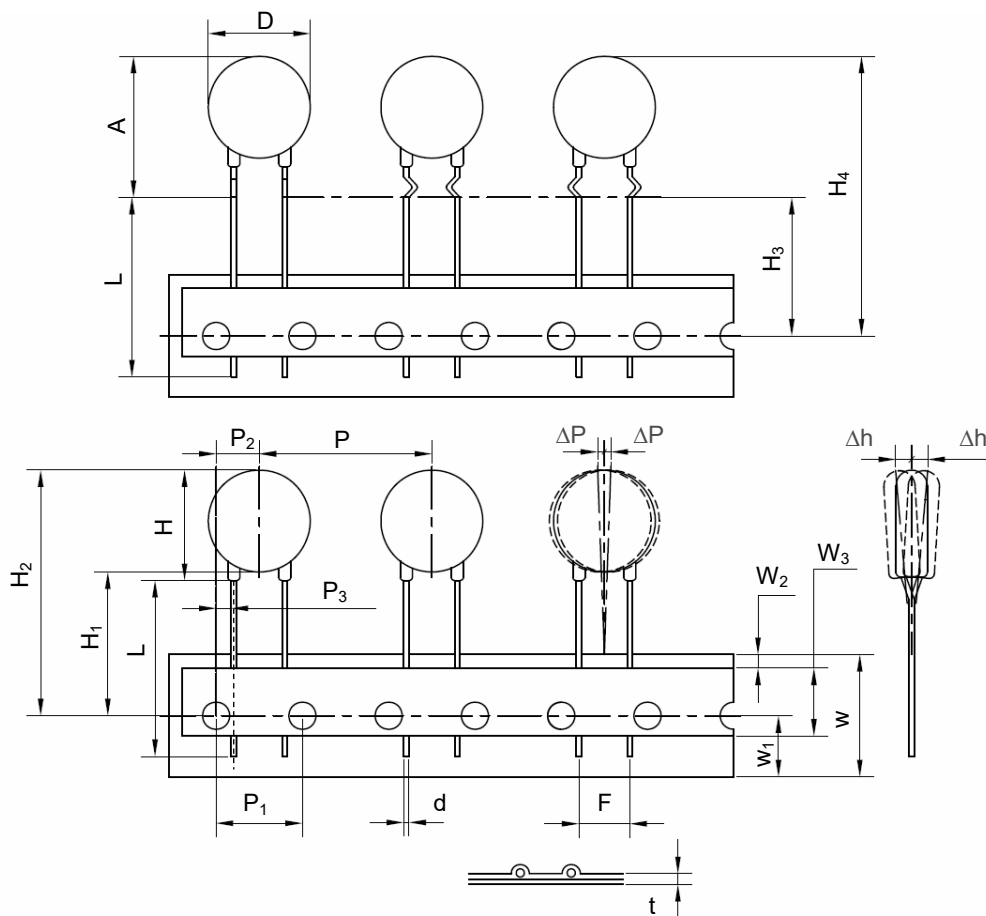

Symbol	Dimensions
P	25.4±1.0
P ₁	12.7±0.3
P ₂	6.35±1.3
P ₃	2.6±0.7
ΔP(max.)	1.0
W	18.0±1.0
W ₁	9.0±1.0
W ₂ (max.)	3.0
W ₃	10.0±2.0
H(max.)	18.5
H ₁	18.0 ^{+2.0} ₋₀
H ₂ (max.)	40.0
H ₃	18.0 ^{+2.0} ₋₀
H ₄ (max.)	42.0
Δh(max.)	2.0
t(max.)	0.6
D(max.)	16.5
D ₀	4.0±0.2
d	0.80±0.05
A(max.)	21.5
F	7.5±1.0
L(min.)	Taping

- Tape Packaging Quantity & Weight.

Series	Nominal Varistor Voltage (V)	Box (PCS)	Carton (PCS)	G. W / Carton (365 × 265 × 415) (kg)±10%
14D	112 - 122	250	1750	10 - 12
	681 - 102	300	2100	9 - 12
	471 - 621	400	2800	9 - 11
	301 - 431	500	3500	8 - 10
	820 - 271	600	4200	6 - 9

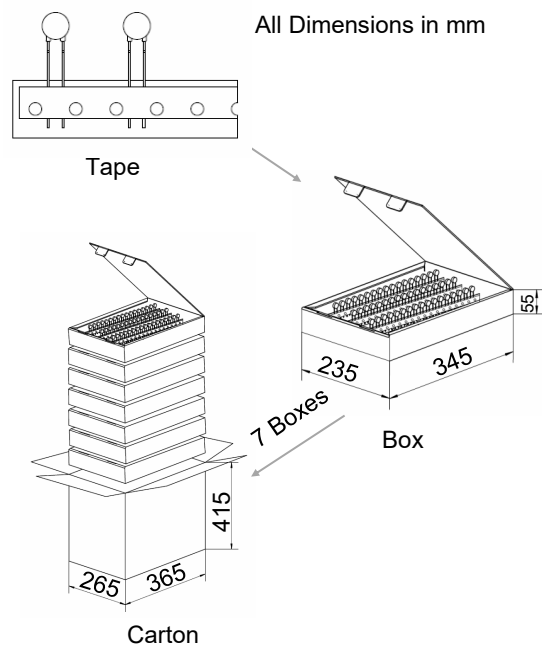

Packaging Information

- Tape Packaging (Code: 1AB)

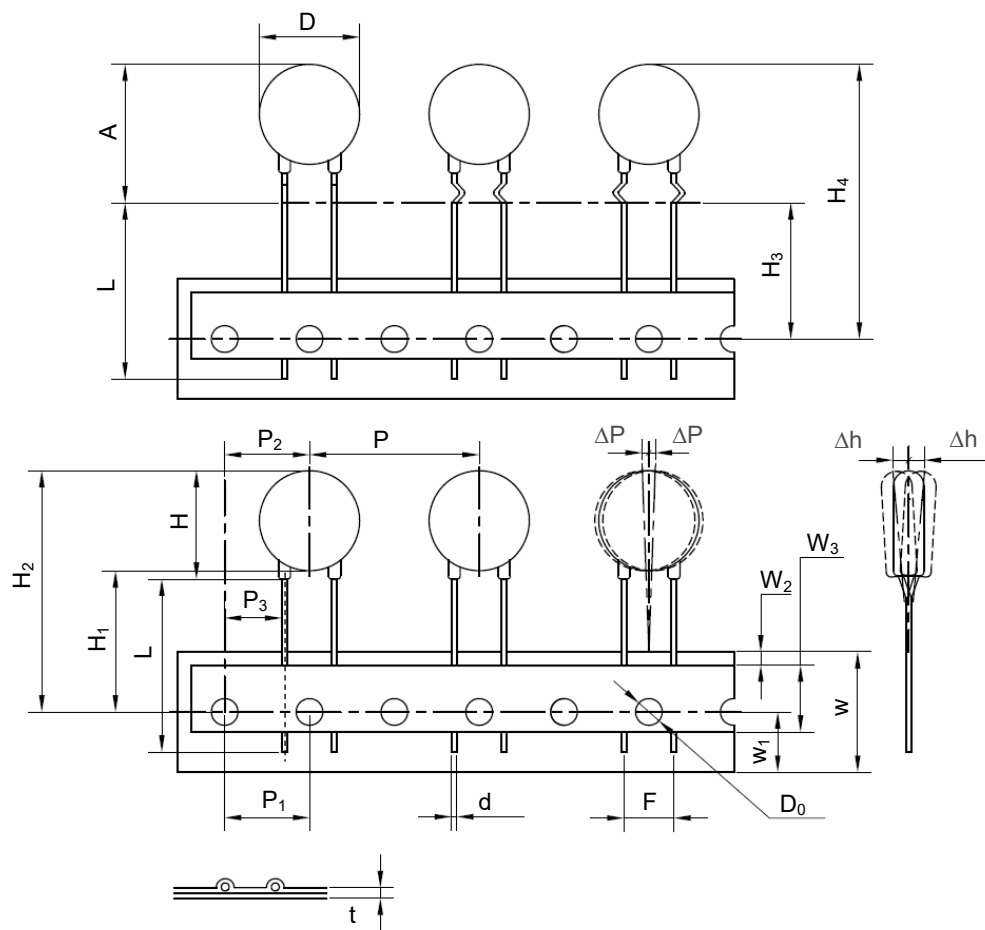

Dimensions (mm)

Symbol	Dimensions
P	25.4±1.0
P ₁	12.7±0.3
P ₂	12.7±1.3
P ₃	8.95±0.7
ΔP(max.)	1.0
W	18.0±1.0
W ₁	9.0±1.0
W ₂ (max.)	3.0
W ₃	10.0±2.0
H(max.)	18.5
H ₁	18.0 ^{+2.0} ₋₀
H ₂ (max.)	40.0
H ₃	18.0 ^{+2.0} ₋₀
H ₄ (max.)	42.0
Δh(max.)	2.0
t(max.)	0.6
D(max.)	16.5
D ₀	4.0±0.2
d	0.80±0.05
A(max.)	21.5
F	7.5±1.0
L(min.)	Taping

- Tape Packaging Quantity & Weight.

Series	Nominal Varistor Voltage (V)	Box (PCS)	Carton (PCS)	G. W / Carton (365 × 265 × 415) (kg)±10%
14D	112 - 122	250	1750	10 - 12
	681 - 102	300	2100	9 - 12
	471 - 621	400	2800	9 - 11
	301 - 431	500	3500	8 - 10
	820 - 271	600	4200	6 - 9

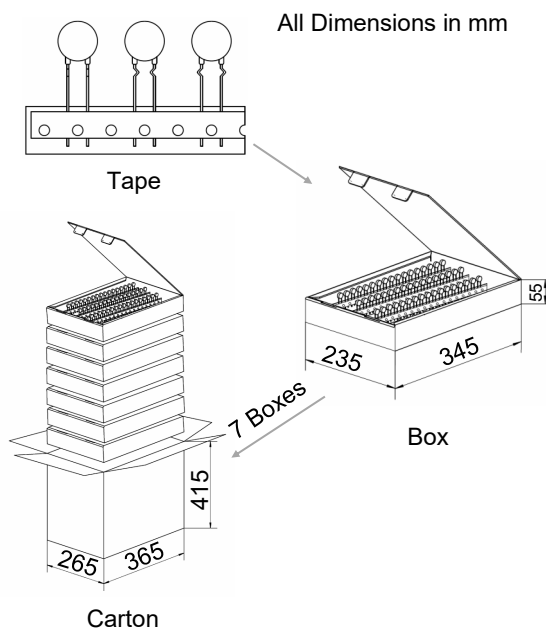

Packaging Information

- Tape Packaging (Code: 0EB)

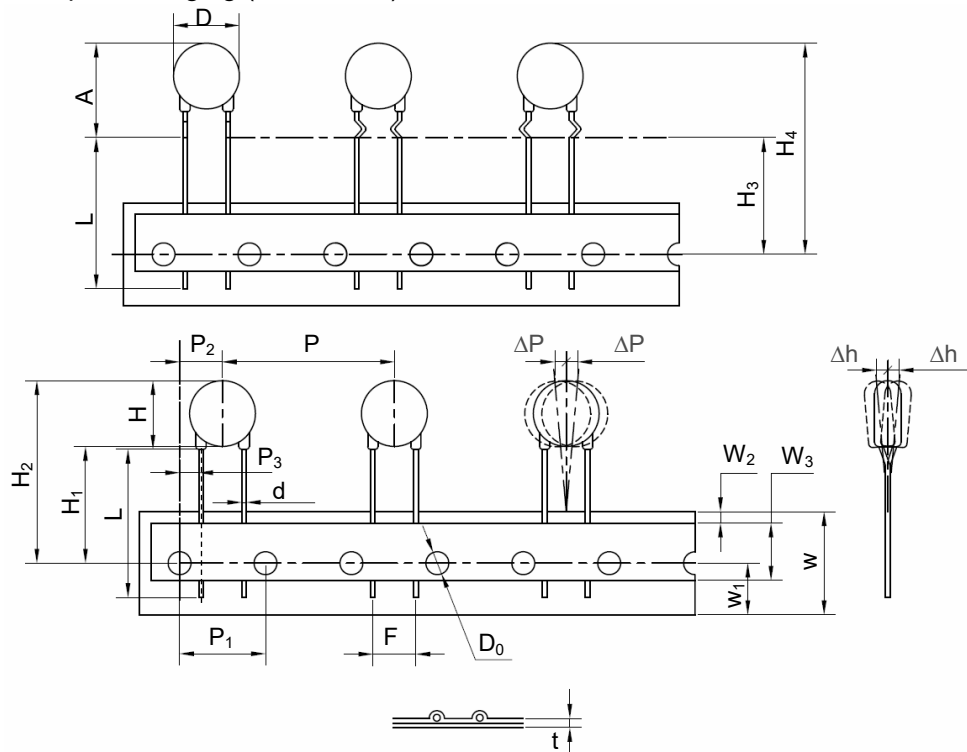

Dimensions (mm)

Symbol	Dimensions
P	30.0±1.0
P ₁	15.0±0.3
P ₂	7.5±1.3
P ₃	3.75±1.0
ΔP(max.)	1.0
W	18.0±1.0
W ₁	9.0±1.0
W ₂ (max.)	3.0
W ₃	10.0±2.0
H(max.)	18.5
H ₁	18.0 ^{+2.0} ₋₀
H ₂ (max.)	40.0
H ₃	18.0 ^{+2.0} ₋₀
H ₄ (max.)	42.0
Δh(max.)	2.0
t(max.)	0.6
D(max.)	16.5
D ₀	4.0±0.2
d	0.80±0.05
A(max.)	21.5
F	7.5±1.0
L(min.)	Taping

- Tape Packaging Quantity & Weight.

Series	Nominal Varistor Voltage (V)	Box (PCS)	Carton (PCS)	G. W / Carton
				G. W / Carton (365 × 265 × 415) (kg)±10%
14D	112 - 122	200	1400	8 - 9
	821 - 102	250	1750	8 - 9
	681 - 751	300	2100	8 - 9
	511 - 621	350	2450	8 - 9
	391 - 471	400	2800	7 - 9
	301 - 361	450	3150	7 - 9
	241 - 271	500	3500	6 - 7
	151			7
	181 - 221			6 - 7
	101 - 121	550	3850	6 - 7
	820			6 - 7

All Dimensions in mm

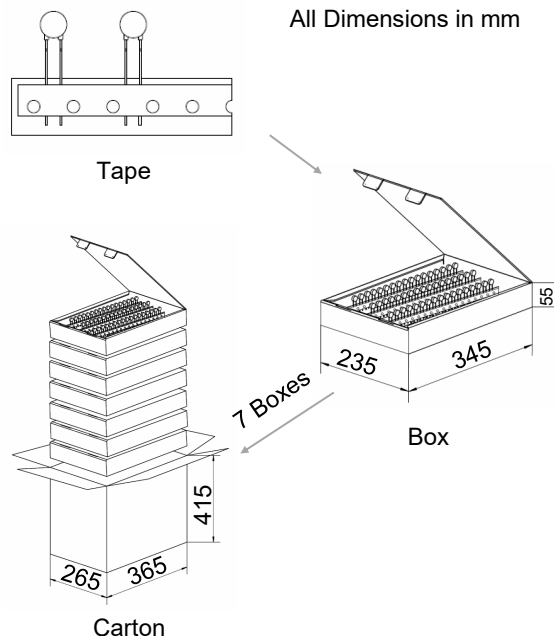

Packaging Information

- Tape Packaging (Code: 1EB)

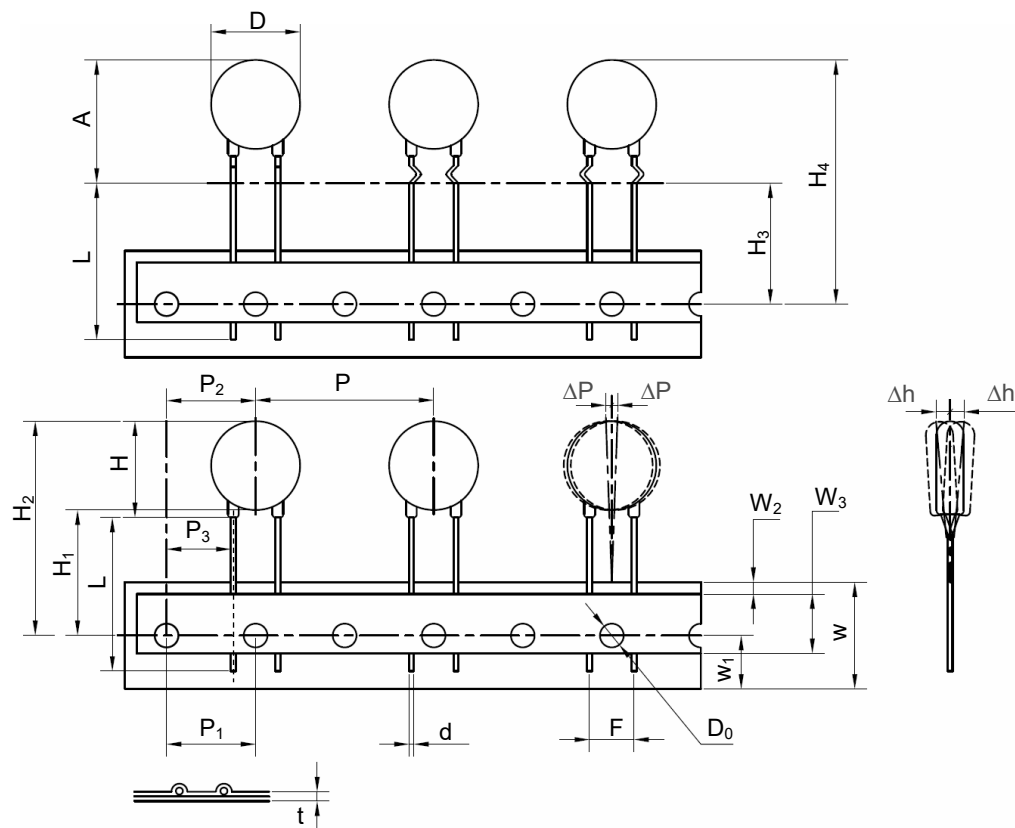

Dimensions (mm)

Symbol	Dimensions
P	30.0±1.0
P ₁	15.0±0.3
P ₂	15.0±1.3
P ₃	11.25±1.0
ΔP(max.)	1.0
W	18.0±1.0
W ₁	9.0±1.0
W ₂ (max.)	3.0
W ₃	10.0±1.0
H(max.)	18.5
H ₁	18.0 ^{+2.0} ₋₀
H ₂ (max.)	40.0
H ₃	18.0 ^{+2.0} ₋₀
H ₄ (max.)	42.0
Δh(max.)	2.0
t(max.)	0.55
D(max.)	16.5
D ₀	4.0±0.2
d	0.80±0.05
A(max.)	21.5
F	7.5±1.0
L(min.)	Taping

- Tape Packaging Quantity & Weight.

Series	Nominal Varistor Voltage (V)	Box (PCS)	Carton (PCS)	G. W / Carton (365 × 265 × 415) (kg)±10%
14D	112 - 122	200	1400	8 - 9
	821 - 102	250	1750	8 - 9
	681 - 751	300	2100	8 - 9
	511 - 621	350	2450	8 - 9
	391 - 471	400	2800	7 - 9
	301 - 361	450	3150	7 - 9
	241 - 271	500	3500	6 - 7
	151			7
	181 - 221	550	3850	6 - 7
	101 - 121			
	820	600	4200	6

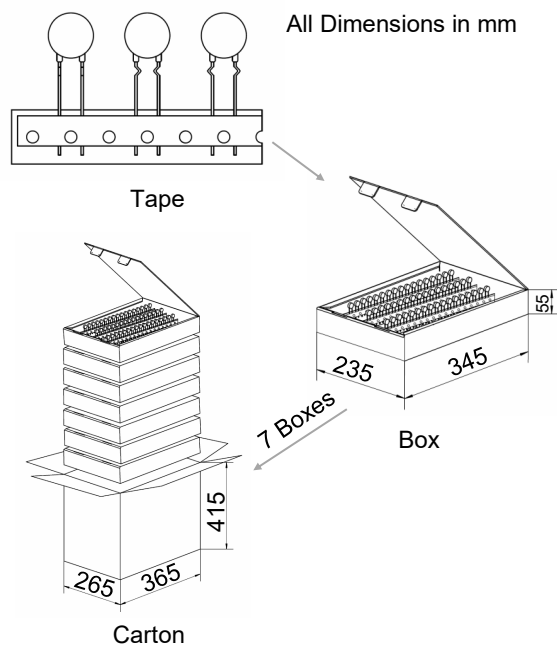

Packaging Information

- Reel Packaging (Code:1AR)

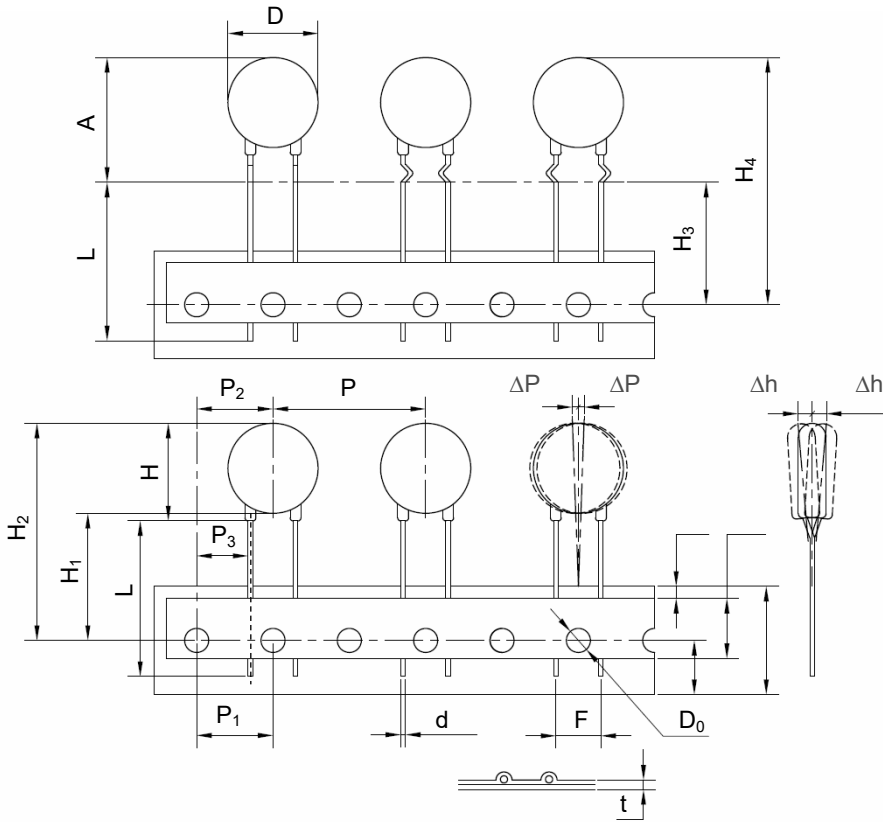

Dimensions (mm)

Symbol	Dimensions
P	25.4±1.0
P ₁	12.7±0.3
P ₂	12.7±1.3
P ₃	8.95±0.7
ΔP(max.)	1.0
W	18.0±1.0
W ₁	9.0±1.0
W ₂ (max.)	3.0
W ₃	10.0±2.0
H(max.)	18.5
H ₁	18.0 ^{+2.0} ₋₀
H ₂ (max.)	40.0
H ₃	18.0 ^{+2.0} ₋₀
H ₄ (max.)	42.0
Δh(max.)	2.0
t (max.)	0.6
D(max.)	16.5
D ₀	4.0±0.2
d	0.80±0.05
A(max.)	21.5
F	7.5±1.0
L(min.)	Taping

- Reel Packaging Quantity & Weight.

Series	Nominal Varistor Voltage (V)	Box (PCS)	Carton (PCS)	G. W / Carton (375 × 335 × 385) (kg)±10%
14D	820 - 301	650	3250	4 - 8
	331 - 681	400	2000	4 - 8
	751 - 122	250	1250	5 - 8

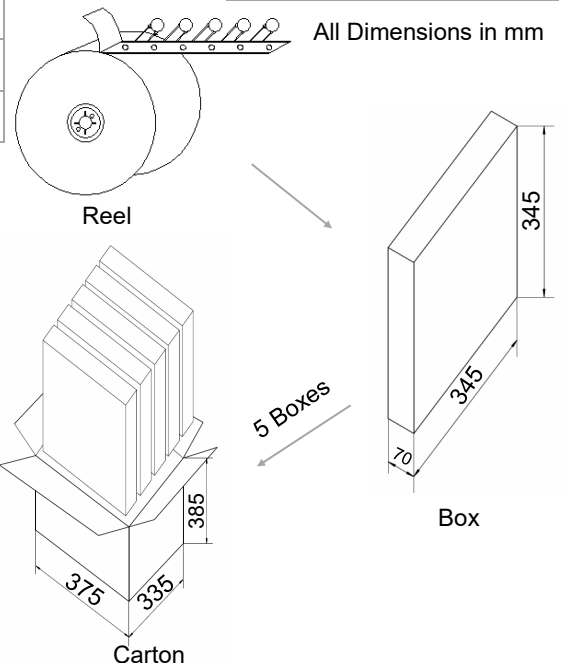
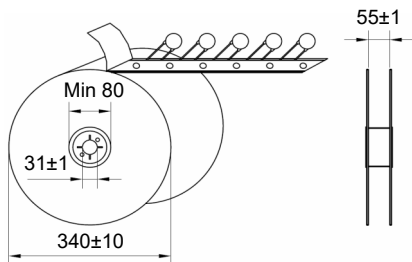



ATTENTION

MOV

MOV

Usage

1. Varistor must operated in the specified ambient temp.
2. Do not clean the varistor with strong polar solvent such as ketone, esters, benzene and halogenated hydrocarbon.
3. Please do not apply severe vibration, shock or pressure to MOV.
4. Please fix lead wires when bending or cutting. The distance between the bending point and the sealing of MOV shall be greater than 2 mm.

Replacement

If varistor is visually damaged, please replace it.

Storage

1. Storage Temp. Range: (-40 to +125) °C
2. Relative Humidity : ≤75% RH
3. Altitude: <2000 m
4. Do not store the MOV at the high temp., high humidity or corrosive gas environment, to avoid influencing the solder-ability of the lead wires, the product shall be used up within 1 year after receiving the goods.

Environmental Conditions

1. Varistor should neither be exposed to the open air, nor direct sunshine.
2. Varistor should avoid rain, water vapor or other condition of high temp. and high humidity.
3. Varistor should avoid sand dust, salt spray, or other harmful gases.

MOV

Metal Oxide Varistor

SFV14D M Series

Max. Typical Capacitance of Varistor

The typical capacitance of varistor is listed in the specifications. Designers may refer to it when designing MOV in high frequency circuit.

Installation

Mechanical Stress

Do not knock MOV when installing, to avoid mechanical damage.